

Three Phase Padmounted and Unit Substation Transformers 45-3000 kVA

Total customer satisfaction through continual process improvement.



“Power and productivity for a better world”



Introduction to ABB, Inc.

ABB's history of innovation goes back more than a century and includes many breakthroughs: the world's first three-phase power transmission system; the world's first self-cooling transformer; the world's first high-speed locomotive with a direct drive system; even the world's first synthetic diamond.

This rate of innovation is the main reason ABB is a global leader in power and automation technologies that enable utility and industry customers to improve performance while lowering environmental impact.

ABB is the recognized leader in power technologies. We provide industrial and commercial customers, as well as electric, gas and water utilities, with a broad range of products, services and solutions for power transmission and distribution.

The ABB Jefferson City plant started as a Westinghouse Electric Corporation facility when the product was transferred from the Sharon, PA plant. The first production unit rolled off the line in May of 1972 and Jefferson City has produced over 2 million transformers to date with Ameren (Union Electric) buying the 1 millionth transformer in January of 1990.

The ABB Jefferson City plant has developed numerous engineering design features such as folded fins to cool both single and three phase transformers, a flexible manufacturing system (FMS) line that fabricates the cabinet assemblies for three phase transformers, and an integrated tank line that fabricates the oil compartment for three phase transformers. Many of the fabrication steps on this line are automated; the line consists of an automated storage and delivery system, turret and laser system, a wing bender, ABB welding robots, and an ergonomic material handling system.



Distribution Transformers

You can rely on ABB as the global leader in transformer technology for more than 100 years. Our products, services and professional expertise are unmatched by any other company in the power industry. That is why customers all over the world choose ABB as their partner in delivering reliable and cost effective energy to their customers.

ABB distribution transformers are uniquely qualified to meet the needs of the Utility, Industrial & Construction, and Energy industries. We are a dominant force in the industry. We lead the way with the introduction of new products and services for the ever-changing distribution transformer industry.

We can offer cost-effective solutions for power distribution. We support our industry with a commitment to product development. We utilize the latest manufacturing technology to maintain state-of-the-art quality and productivity. Extensive vertical integration allows us to ship high quality products in the shortest possible production cycle. We are in alliances with major utilities and businesses around the world providing products and services to meet all their needs.

ABB will continue to build on a heritage of quality, customer satisfaction and technology, and capitalize on its resources, to maintain its position as the number one supplier of transformers in the industry.

ABB Three Phase Padmounted Distribution Transformers are designed for maximum tamper resistance since the units are used to service shopping centers, schools, institutions and industrial plants. ABB offers an improved cabinet



design that features a one piece sloped cabinet weather cover to effectively shed water and allow easier access into the cabinet compartment. Units may be furnished in a complete line of ratings and in a wide range of configurations to meet customer needs.

Unit Substation transformers are generally close coupled to switchgear, motor control, bus duct, or another type of incoming and outgoing equipment. ABB's proven design offers excellent mechanical strength that has been proven through years of service and special testing.

ABB offers submersible transformers for diverse commercial and residential underground applications. Submersible transformers are designed for use in underground vaults to offer flexibility, safety, and easy accessibility for operating personnel. The ABB design can incorporate all of your switching and fusing needs in one unit.



More Value Inside and Out

ABB delivers an unmatched package of added value, from the moment you entrust your purchase order to us. We are focused on delivering value every step of the way – from precise specification conformance to assured on-time delivery, and from efficient performance to effective emergency response.

Those values add up, and this is where ABB Distribution Transformers far exceed the competition – making us your single source for high value distribution products. We have built a heritage of operational excellence and unmatched customer service while delivering unique solutions. By combining high quality materials with our commitment to continual process improvement, we provide custom transformers to meet your specific needs.

Our commitment to reliability is the foundation that assures the longest life-cycle for our transformers. With lower customer life-cycle cost, you have added value in every transformer.

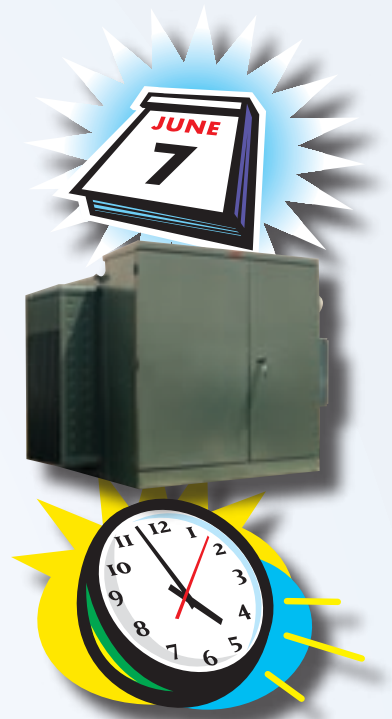

Quality Pays Off

ABB's continual process improvement and vast experience in transformer design and manufacturing assures uncompromising quality and total customer satisfaction. This avoids the problem of installing a transformer only to find it's not working properly, avoiding project delays, cost overruns, and customer dissatisfaction with lack of electrical services.



Manufacturing Technology

ABB Distribution Transformers are manufactured with high quality materials and components which are tested under stringent conditions. This ensures that ABB transformers meet the highest standards anywhere in the world. When specified, we can design our products to handle the harshest environments.



ABB has a rich heritage of technology development and innovation and has pioneered many of the features you see in today's transformers. This includes the introduction of foil windings and wound core technology which significantly

increase reliability and safety. Designs are properly adapted to modern manufacturing technologies aimed at maintaining the highest quality standards and keeping costs competitive.

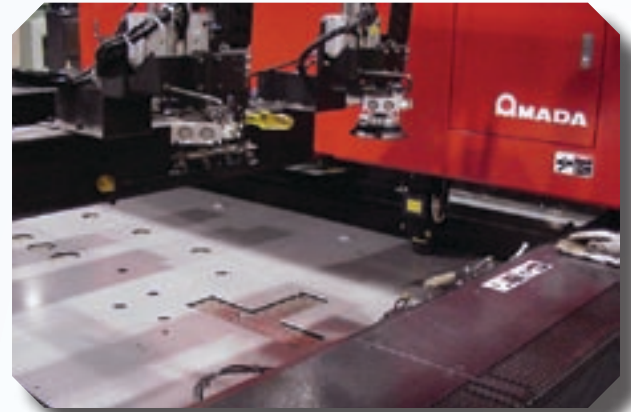

Timely Delivery



You can be assured that we will meet our delivery commitments, be it to current or contracted lead times or in response to emergencies. When we agree on a delivery schedule, we'll make sure your transformers are on site and ready to install.

If transformers arrive too early, they can get in the way on the job site, and if they arrive late it's much worse. ABB makes sure that your padmounted transformers arrive when you need them, so your work can proceed seamlessly.

Distribution Transformer Testing

The ABB commitment to manufacture quality distribution transformers is backed by a series of transformer tests used to verify conformance to performance characteristics outlined in the latest revisions of IEEE C57.12.00 and IEEE C57.12.90. These identified tests are also part of the Quality System which is audited semi-annually by DET NOSKE VERITAS (DNV) to the ISO Standards.

Testing Program

Factory tests are performed on a transformer to confirm that it is properly designed and constructed to carry rated load and that it will withstand the conditions it will be exposed to in service.

Each transformer manufactured by ABB must undergo a series of tests.

1. Polarity, Phase-Relation, and Ratio
2. Demag Test
3. Applied Voltage Test of the HV
4. Applied Voltage Test of the LV
5. Induced Voltage Test
6. No-Load (Excitation) Loss and Excitation Current
7. Impedance Voltage and Load Loss
8. Full Wave Impulse
9. Continuity Check

Test Facilities

The multi-station, automated test facilities are operated by process control computers. Required interaction with test floor personnel is minimal with the computers initiating and monitoring each test, and then analyzing the test results feedback. The computers are programmed to conduct tests according to IEEE standards, and according to the ratings of each transformer style, the test floor computers will initiate appropriate test setups, compare results with established IEEE standard limits, and determine acceptance for each tested unit.

The test results for each unit are recorded and stored on computer files for access and analysis.

Polarity, Phase-Relation, and Ratio Tests

These tests verify proper phase-relation (three phase), ratio, and polarity (single phase) of the transformer under test. To pass, a unit must demonstrate the proper polarity or phase-relation and have a turns ratio within one-half of one percent of the nominal voltage ratio.

Demag Test

Some transformers require the Demag Test to remove any residual magnetism in preparation for an impulse test. It also serves as a no-load exciting current test. A transformer passes this test if the exciting current does not exceed the limit specified for the design of the transformer.

Applied Voltage Test of the HV

This test checks the dielectric integrity of insulation structures between the high voltage and low voltage, and between the high voltage and ground. A pass/fail decision is made by monitoring the test current intensity. If the resulting current is larger than specified normal leakage and capacitive currents, the unit is rejected. This test is omitted for transformers with a permanently grounded high voltage winding.

Applied Voltage Test of LV

This dielectric test is similar to the Applied Voltage test of the high voltage circuitry except that the integrity of insulation structures between the low voltage and the high voltage, and between the low voltage and ground is checked. A pass-fail decision is made by monitoring the test current intensity. If the resulting current is larger than specified normal leakage and capacitive current, the unit is rejected.

Induced Voltage Test

The principal purpose of this test is to verify the dielectric strength of turn to turn, layer to layer, phase to phase, and other insulation structures within the transformer windings by inducing an overvoltage condition (at higher than normal frequency to avoid saturation of the core). The test current is monitored, and if it exceeds limits specified for each transformer, the unit is rejected.

No-Load Loss and Excitation Current

This test measures the no-load (excitation) loss and the transformer exciting current with rated voltage applied. If the exciting current and/or the no-load loss exceed the limits specified, the transformer is rejected.

Impedance Voltage and Load Loss

This test measures the load loss and the impedance voltage at rated current. The load loss and the impedance voltage must be within specified limits.

Full Wave Impulse

The impulse test is one of several tests designed to verify the dielectric strength of the many insulation structures within the distribution transformer against line voltage surges. It is performed to comply with IEEE standards and for quality assurance. The change in the IEEE standard in 1993 required all manufacturers to install fault detection sensitive enough to detect a single turn short.

Continuity Check

This test is performed on all transformers to verify transformer circuit and component integrity. This test is performed with an ohmmeter to verify that the internal wiring is correct.

The transformer's nameplate is compared to manufacturing information for style, serial number, kVA, HV rating, LV rating, tap voltages, impedance, conductor materials and coil BIL rating. The bushings, electrical accessories, and fuses are verified.

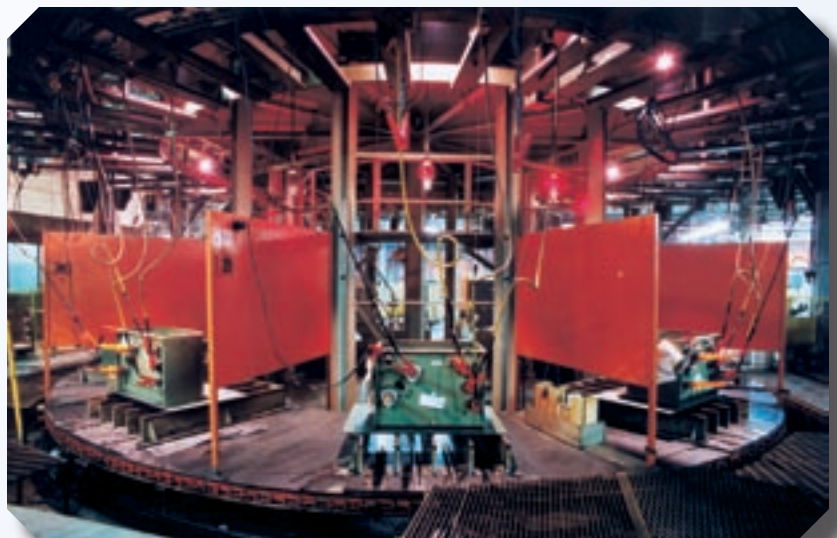

Special Tests

Some tests are performed at the option of the customer.

Sound Testing

IEEE standards define the required sound levels for transformer but some customers specify reduced sound levels. The sound generated by a transformer is affected by the core geometry, flux density, tank design, and the quality of assembly of all the transformer components into a completed unit. Sound tests are made with the unit powered at 100% and 110% of rated voltage under no-load conditions.

Temperature Tests

Core losses and coil losses are the primary sources of heating within the transformer. Our transformers are guaranteed to have an average coil winding temperature of no more than 65° C rise over ambient air temperature when operated at rated voltage and load conditions.

The temperature test is performed to determine the thermal characteristics of the transformer and to verify that they are within design limits.

Calibration

Test equipment is calibrated on a scheduled basis by trained technicians. Calibration records are maintained in accordance with the Quality System procedures. These are audited semi-annually by DNV in accordance with ISO Standards.

Short Circuit Withstand Capabilities

Distribution transformers are subjected to external short circuits on the secondary side. Such external faults can develop on the service line, in the house wiring or in connected loads due to numerous environmental reasons. These faults can be line-to-ground, double line-to-ground or line-to-line.

To meet these operating conditions, the American National Standard Institute (IEEE) has set standards concerning short circuit withstand capability. These standards require that distribution transformers shall be designed and constructed to withstand the mechanical and thermal stresses produced by these external short circuits.

The current standards relating to short circuit strength are IEEE C57.12.00 which sets the short circuit withstand requirements for distribution transformers and IEEE C57.12.90 which provides procedures for short circuit testing.

For distribution transformers, the magnitude of the short circuit current, the numbers of short-circuit tests and the duration of each short circuit test are defined by IEEE standards as follows.

A. Magnitude

Category	Single Phase kVA	Three Phase kVA	Withstand Capability*
I	5-25	15-75	40
	37.5-100	112.5-300	35
	167-500	500	25
II		750-2500	1/Z _{T**}

*Base current (Symmetrical) per unit for all distribution transformers with secondary rated 600 V and below.

**The short circuit current will be limited by the transformer impedance only.

B. Number of Tests

Each phase of the transformer shall be subjected to a total of six tests, four with symmetrical fault currents and two with asymmetrical fault currents.

C. Duration of Short Circuit Tests

When short circuit tests are performed the duration of each test shall be 0.25 s except that one test satisfying the symmetrical current requirement shall be made for a longer duration on distribution transformers. The duration of the long test in each case shall be as follows:

Category I:

$$T = 1250/I^2$$

Where T is the duration in seconds,

And $I = I_{sc}/I_R$ = symmetrical short circuit current, in multiples of normal base current except I shall not exceed the maximum symmetrical current magnitudes listed in A.

Where $I_{sc} = I_R/Z_T$ = symmetrical short circuit current, in rms amperes

I_R = rated current on the given tap connection, in rms amperes

Z_T = transformer impedance on the given tap connection in per unit on the same apparent power base as I_R

Category II:

$$T = 1.0 \text{ second}$$

Criteria of Satisfactory Performance

According to IEEE Standards a unit is considered to have passed the test if it passes a visual inspection and dielectric tests. Recommended additional checks include examination of wave shape of terminal voltage and current, leakage impedance measurement and excitation current test. (Refer to IEEE C57.12.90.)

The standard allows the following variations in the leakage impedance:

Z _T (Per Units)	Percentage Variation
0.0299 or less	22.5-500 (Z _T)
0.0300 or more	7.5

Z_T = per unit impedance of the transformer

Paint Finish Process

ABB utilizes a multi-step process to apply a corrosion resistant finish to transformers. The materials and processes used are designed to protect against the effects of abrasion, sunlight, rural and industrial atmospheres, and humidity. Each carefully controlled process step has a specific purpose, and each step builds on the previous steps to form the complete protection system that ensures that our transformers meet IEEE functional paint specification guidelines.

Paint Process Procedure

Transformer parts receive the following steps of surface preparation prior to painting.

1. Abrasive cleaning: All parts are cleaned or prepped to remove welding by-products and provide more consistent adhesion and corrosion protection.
2. Alkaline wash cleaner: Removes mill oils, drawing oils, and shop soils that could interfere with good adhesion.
3. Water rinse.
4. Iron phosphate coating: Provides a firm anchor for good paint adhesion and provides resistance to underfilm corrosion should the paint film be damaged, exposing bare metal.
5. Water rinse.
6. Deionized water rinse: Removes any ionic contamination to prepare for first application of paint.

The entire cleaning and pretreating process is automatic and conveyORIZED with all chemicals applied by spray. The pretreatment system combines the latest in cleaning technology such as DI rinses and iron phosphate over abrasive cleaning in a tried and true format to provide the best possible pretreatment before paint is applied.

One of the keys to effectiveness of the ABB paint finish system is the primer. The green epoxy primer is applied by cationic electrodeposition – a dip process in which positively charged primer particles are attracted to grounded parts (cathodes). This method applies a very uniform, pinhole-free coating which penetrates and thoroughly coats all parts. This is a highly effective process for coating parts with difficult geometry. The process utilizes practically 100% of the primer paint, and since the primer is water borne OSHA and EPA emission standards are met. The primer is free of lead and chrome. After rinsing, parts are cured in an oven in preparation for the next step.

After the transformer is assembled, a final coating of two-component urethane paint is spray applied for color and additional film build. The final coat provides the weatherability necessary to protect the unit from sunlight and maintain its appearance.



Summary

The ABB paint system utilizes advanced techniques and materials to provide a superior finish system on padmounted distribution transformers. Each step in the process is specifically designed to maximize finish performance while minimizing waste to provide the best possible combination of performance.

Paint Finish Specifications and Test Results

Parameter	Test Method	Specification	Typical ABB Value
Total exterior film build	Elcometer 456 Basic F	Not specified by IEEE	2-4 mils
Adhesion	ASTM D3359 Method A or B	100%	100%
Humidity 1000 hrs.	ASTM D4585 @45c	No blisters, up to 1 pencil hardness change per ASTM D3363	No blisters, no softening
Impact, 80 InLb	ASTM D2794/ ASTM B117	No red rust after 24 hrs.	No red rust after 24 hrs.
Oil resistance	Immerse in 100c Oil for 72 hrs.	No loss of adhesion per ASTM 3359, no blisters, no streaking, up to 1 pencil hardness change per ASTM D3363	No loss of adhesion, no blisters, no streaking, no change in hardness, color or gloss
QUV, 500 hrs.	ASTM G53/D523	50% loss of gloss, no cracks, no crazing	40% loss of gloss, no cracks, no crazing
Abrasion, 3000 cycles	ASTM D4060 24 hrs.	No red rust after 24 hrs.	No red rust after 24 hrs.
Gravelometer, 60 PSI	ASTM 3170/ SAE J400	After 24 hrs. red rust in chips to not exceed 4B rating	4A (better than 4B)
QUV/SCAB, 15 cycles	ASTM G53	6 rating per ASTM D1654, no blisters	6 rating per ASTM D1654, no blisters

Paint meets or exceeds IEEE C57.12.28 and EEMAC Y1-2, Canadian Standard.

Individual product specification sheets located in folder.



Pad-Pak Padmounted Switching Units

An oil-filled padmounted sectionalizing, tapping and fusing device suited for diverse applications.

The Pad-Pak can be furnished in a complete line of ratings and in a wide range of configurations to meet the reliability, safety and operating requirements of any distributions system. It is available in either live front or dead front construction. It is available in 1, 2, or 3 pole ratings, depending on the configuration.

Ratings

200A continuous

Voltages:

4160Y/2400-34500Y/19920

95, 125 and 150 KV BIL

The Pad-Pak meets the following industry Standards:

IEEE C37.72

IEEE C57.12.00

IEEE C57.12.28

Standard Features

1. The Pad-Pak is equipped with 200A externally replaceable universal bushing wells. Parking stands are located near each bushing for attachment of bushing accessories.
2. Each Pad-Pak includes a flip-top hood with heavy-duty 3/8" thick removable stainless steel hinge pins to provide safe and durable service.
3. A recessed locking assembly containing padlock provisions and a locking bolt is standard for tamper-resistant operation. Specify penta-head or hex-head bolt.
4. All tanks are constructed of heavy gauge steel. All tank seams are welded, and every unit is inspected and pressure-tested for leaks before shipment. In addition, all Pad-Paks are supplied with:
 - a. 5/8" – 11 stainless steel lifting bosses
 - b. 1/2" Oil level plug
 - c. Self-actuating pressure relief device in 1/2" oil fill plug
 - d. 1/2" Oil drain plug
 - e. Ground bosses

The fully adjustable and removable sill is provided with cleats for anchoring the sill to the pad.

Tamper-resistant design that exceeds IEEE C57.12.28.

Each unit receives the same metal treatment and paint finish as padmounted transformers. This consists of a multi-step process:

- a. Alkaline cleaning and zinc phosphate coating



- b. Epoxy primer uniformly applied by cationic electrodeposition
- c. Two-component urethane top coat for added UV protection. Color is Munsell 7GY/3.29/1.5 green.

Corrosion resistant nameplate with schematic diagram.

Optional Features

1. Overcurrent Protection:
mounted in a dry well loadbreak canister; sealed to prevent condensation.

Voltage Class 8.3, 15.5, 23 KV
Fuse Type CX, CLT, NX
2. Switching:
 - a. Externally operated loadbreak oil rotary (LBOR) switch

Continuous current 300A
Loadbreak 300A @ 25 KV
Loadbreak 200A @ 38 KV
Momentary 10,000A RMS Sym.
Fault Close 10,000A RMS Sym.
Impulse 125, 150 Kv BIL
Voltage Class 25, 35 KV
3. Primary Connection:
 - a. 200A universal bushing wells and loadbreak inserts
 - b. Integral (one piece) 200A loadbreak bushings
 - c. 200A universal bushing wells and nonloadbreak inserts
 - d. Integral (one piece) 200A non-loadbreak bushings
 - e. 300A porcelain bushings
4. Miscellaneous:
 - a. NEMA safety label per NEMA publication 260-1982

Design Dimensions and Weights

(All weights and dimensions are approximate. Dimensions may change to meet specific customer requirements. Weights are in pounds.)

Nameplate Information

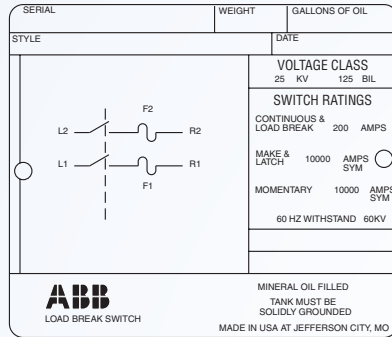

Recommended Pad Dimensions

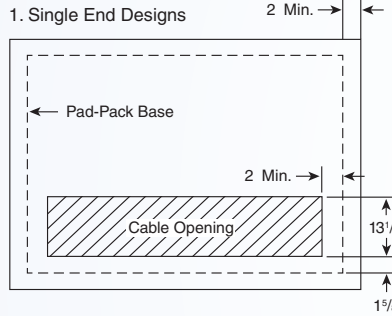

Single Phase

Drawing Schematic	Front View	KV BIL	H	W	D ^②	Weight
1		95	24"	24"	33.3"	475
		125	24"	24"	36"	480
		150	24"	24"	36"	480
2		95	24"	24"	37.8"	560
		125	24"	24"	46.3"	680
		150	①	①	①	①
3		95	24"	36"	33.3"	670
		125	24"	36"	36"	680
		150	24"	36"	36"	680
4		95	24"	36"	33.3"	670
		125	24"	36"	36"	680
		150	24"	36"	36"	680
5		95	24"	40"	37.8"	870
		125	24"	40"	46.3"	1060
		150	①	①	①	①
6		95	24"	36"	37.8"	795
		125	24"	36"	46.3"	965
		150	①	①	①	①
7		95	24"	36"	33.3"	670
		125	24"	36"	36"	680
		150	24"	36"	36"	680
8		95	32"	44"	33.3"	1090
		125	32"	44"	36"	1100
		150	32"	44"	36"	1100
9		95	32"	44"	37.8"	1290
		125	32"	44"	46.3"	1565
		150	①	①	①	①

Three Phase

10		95	32"	40"	39.8"	1265
		125	32"	40"	42.5"	1275
		150	32"	40"	42.5"	1275
11		95	32"	44"	39.8"	1390
		125	32"	44"	46.3"	1565
		150	①	①	①	①

① Contact Division for availability.

② Overall Depth. Hood depth at 95 KV BIL is 16.5", at 125 and 150 KV BIL is 19.5".



ABB Inc.
Distribution Transformers
500 West Highway 94
Jefferson City, MO 65101
USA
Phone +1 573 634 2111
Fax +1 573 659 6275
www.abb.com/transformers



Three Phase Secondary Unit Substation Transformer

A Unit Substation is a liquid-filled transformer for commercial, industrial, and utility application. It is normally packaged with high voltage equipment, low voltage switchgear, panel boards, or motor control centers.

Standard Features:

1. Porcelain high voltage bushings
2. Welded-on tank cover
3. Bolted handhole cover(s)
4. Stainless steel ground pads
5. The paint finish process applies a durable, corrosion resistant finish to the product. The multi-step process includes an epoxy primer uniformly applied by cationic electrode-position and a urethane top coat
6. ANSI 61 gray
7. Oil fill plug
8. Drain Valve w/sampler
9. Epoxy externally clamped secondary bushings with aluminum or copper conductor with integral external spade
10. Anodized aluminum nameplate
11. Four lifting lugs
12. Liquid Level Indicator
13. Liquid Temperature Indicator
14. Pressure Relief Valve
15. Mineral Oil Insulating Fluid
16. 65 degree C average winding rise
17. NEMA 3R 18" deep full height Air Terminal Chamber (ATC) provided on both high voltage and low voltage sides. ATC's can be top feed or bottom feed application
18. Air terminal chamber has bolted on removable covers
19. De-energized externally operable HV tap changer
20. Aluminum windings



Optional Features:

1. 24", 30" and 36" deep ATC
2. Partial height ATC at same depths as full height ATC
3. Removable hinged covers for ATC
4. Throats and flanges
5. Winding Temperature Rise Indicator
6. Cover mounted pressure relief device with semaphore
7. Alarm contacts:
 - a. Liquid Level Indicator
 - b. Liquid Temperature Indicator
 - c. Pressure Relief Diaphragm
 - d. Rapid Pressure Relay
 - e. Pressure Vacuum Gauge
 - f. Winding Temperature Rise Indicator
8. Cooling fans with control package or provisions for future fans
9. Some special paint colors – contact factory for available colors
10. 55 degree C average winding temperature rise
11. Neutral grounding resistors – contact factory for availability
12. Distribution class surge arresters
13. Pressure Vacuum Gauge
14. NEMA 4x control box
15. Copper windings
16. UL certification

Ratings

150-3000 kVA, 3 phase, 60 hertz standard, 50 hertz optional
 High Voltages (150 kv BIL and below): 4160 through 34,500Δ
 Low Voltages (60 kv BIL and below):

150 kVA through 1000 kVA: 2300Δ, 2400Y/1385 to 4160Δ,
 4160Y/2400, 480Y/277, 480Δ, 208Y/120

1500 kVA through 3000 kVA: 2300Δ, 2400Y/1385 to 4160Δ,
 4160Y/2400, 480Y/277, 480Δ

Design Dimensions

(All dimensions are approximate. Dimensions may change to meet specific customer requirements.)

kVA	W Inches	H Inches	D Inches	Wt. Lbs.	Gal. of Oil
225	46	73	50.5	5870	480
300	46	73	50.5	6035	477
500	50	73	52.2	7192	517
750	53	73	50.5	9150	566
1000	62	73	71	10521	642
1500	66	73	67.4	12427	665
2000	69	73	67.4	15021	668
2500	69	73	93.1	17334	662
3000	69	85	93.1	19000	699

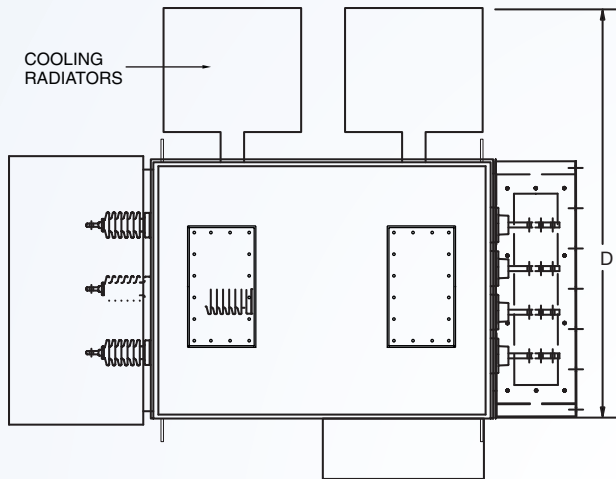

TOP VIEW

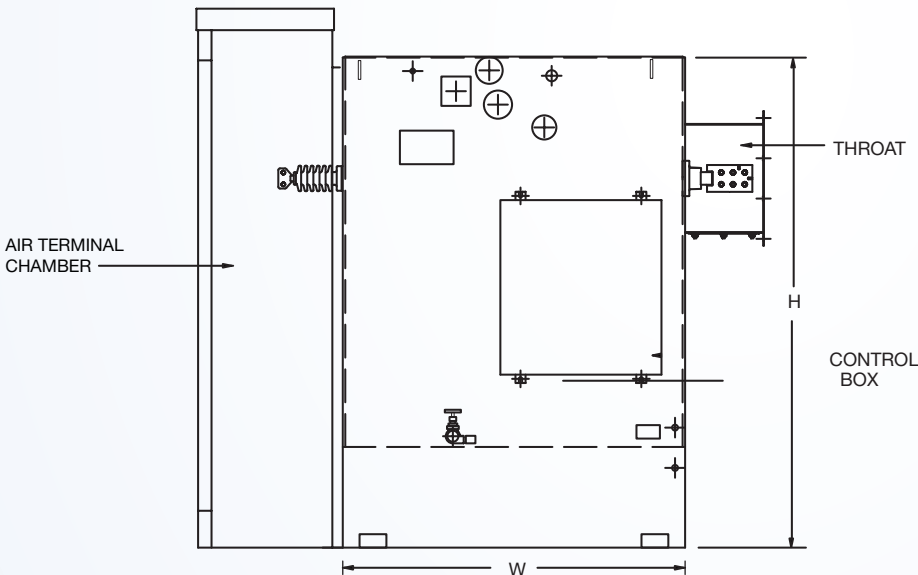

FRONT VIEW

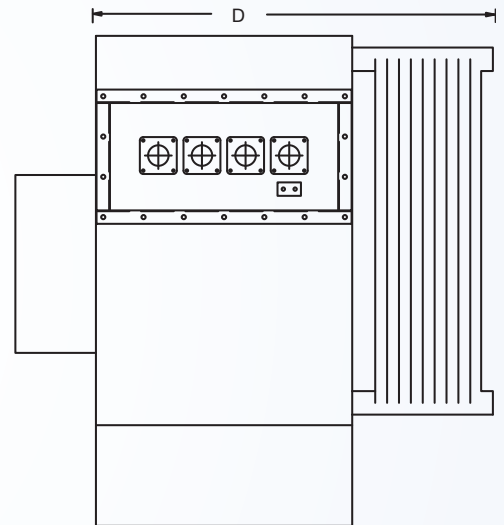

RIGHT VIEW



ABB Inc.
 Distribution Transformers
 500 West Highway 94
 Jefferson City, MO 65101
 USA
 Phone +1 573 634 2111
 Fax +1 573 659 6275
www.abb.com/transformers

MTP Mini-Three Phase Padmounted Transformer

The Mini-Three Phase Padmounted Transformer (MTP) is designed for the needs of utility customers to reduce costs and improve aesthetics. The design is easier to handle, install and maintain. The discreet profile of the MTP is ideal for commercial applications such as banks, stores and restaurants.

The MTP features a hood and removable sill instead of doors. The design allows easy access for installation and maintenance of the transformer.

The ABB MTP meets the following industry standards:

IEEE C57.12.00 NEMA TR-1
IEEE C57.12.26 IEEE C57.12.28
IEEE C57.12.29 WUG 2.13, Rev. 4
IEEE C57.12.70 IEEE C57.91
IEEE C57.12.80 IEEE C57.12.90

Ratings @ 65° C Rise:

KVA: 45-150 kVA
HV: 4160GY/2400 through 24940Y/14400V Δ at 95 BIL spacing only, 2400 Δ through 14400 Δ at 95 BIL spacing only
BIL: 60, 75, 95 kV
LV: 208Y/120, 216Y/125, 460Y/265, 480Y/277, 480 Δ , 240 Δ and 240 Δ with 120 volt mid-tap in one phase 60 hertz standard, 50 hertz optional

Standard Features:

1. A flip-top hood and heavy duty 3/8", removable stainless steel hinge pins provide safe and durable service.
2. A recessed locking assembly with padlock provisions and a penta-head locking bolt is standard for tamper-resistant operation. A hex-head locking bolt is available.
3. All tanks are constructed of heavy gauge steel. Tank seams are welded and each unit is pressure tested and inspected for leaks prior to shipment.
4. The front sill latches with the flip-top hood, is attached on the side of the tank and is removable.
5. The high voltage universal bushing wells are externally clamped and removable. A parking stand between the bushing wells is provided for attachment of bushing accessories.
6. Externally clamped low voltage bushings.



7. Loop or radial feed, dead front only for high voltage configurations. Loop pattern will be loop "V" with minimum dimensions per IEEE C57.12.26, Fig. 2 at 8.3/14.4 kV. Radial pattern will be either horizontal with minimum dimensions per IEEE C57.12.26, Fig. 1 or a non-IEEE slant pattern.
8. Standard low voltage pattern is the staggered arrangement per IEEE C57.12.26, Fig. 4a with minimum dimensions.
9. Cabinet depth is standardized to be 19 inches.
10. Tamper-resistant design that exceeds IEEE C57.12.28
11. NEMA safety labels
12. Nameplate
13. Five legged core/coil assembly
14. The paint finish process applies a durable, corrosion resistant finish to the product. The multi-step process includes an epoxy primer uniformly applied by cationic electrodeposition and a urethane top coat.

Optional Accessories:

1. Standard fusing is bayonet with or without under oil partial range current limiting fusing.
2. Taps or delta x wye or dual voltage are available, but not combined with each other.
3. One loadbreak oil switch is possible.
4. A live HO bushing is possible in the high voltage compartment.
5. A high-low barrier will be either metal or glasspoly.
6. Stainless steel designs, including the Mini-Skirt, are available.
7. Full range general-purpose current limiting fuses in dry well canisters will only be available in radial units with single fuse application.
8. Special slant low voltage pattern available upon request. This feature allows more space to mount metering current transformers.
9. Substation accessories available (normally in the low voltage compartment).

Minimum/Maximum Design Dimensions

(All dimensions are approximate. Dimensions may change to meet specific customer requirements. Dimensions are in inches.)

MTP	A	B	C	D
Min.	36	44	51.5	19.25
Max.	42	44	57.5	19.25

Design Dimensions:

Physical data is approximate and is based on single voltage units with or without taps, with standard 19.25" cable compartment depth. Dimensions are in inches. Weights are in pounds. Dimensions may change to meet specific customer requirements.



ABB Inc.
Distribution Transformers
500 West Highway 94
Jefferson City, MO 65101
USA
Phone +1 573 634 2111
Fax +1 573 659 6275
www.abb.com/transformers



Three Phase Padmounted Transformer

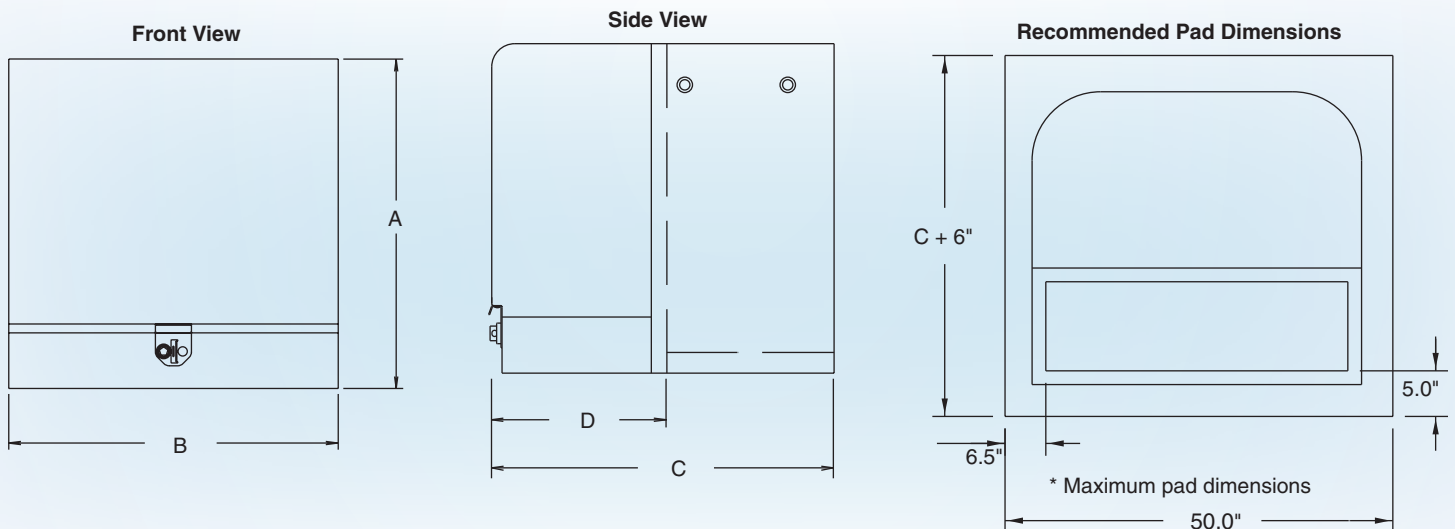

The ABB MTR is an oil-filled, three-phase, commercial padmounted distribution transformer specifically designed for servicing such underground distribution loads as shopping centers, schools, institutions and industrial plants. It is available in both live front and dead front construction, for radial or loop feed applications, with or without taps.

ABB MTR meets the following industry standards:

IEEE C57.12.00 IEEE C57.12.80
IEEE C57.12.28 IEEE C57.12.90
IEEE C57.12.29 IEEE C57.91
IEEE C57.12.34 NEMA TR1
IEEE C57.12.70

Ratings:

- 45 through 3000 kVA
- 65° C average winding rise
- 60 hertz standard, 50 hertz optional

45-1500 kVA

- High voltages: 4160 Grd Y/2400 through 34,500 Grd Y/19,920 for Grounded Wye systems; 2400 through 34,500 for Delta systems; various dual high voltages

2000-3000 kVA

- High voltages: 7200 Grd Y/4160 through 34,500 Grd Y/19,920 for Grounded Wye systems; 4160 through 34,500 for Delta systems; various dual high voltages
- Taps: All voltages are available with or without taps
- Insulation classes: 35 kV, 150 kV BIL and below

45-1500 kVA

- Low voltages: 208Y/120, 216Y/125, 460Y/265, 480Y/277, 480Δ, 240Δ and 240Δ with 120 volt mid-tap in one phase; (4160Y/2400, 4160Δ, 2400Δ, 2400/4160Y/2400 for 1500 kVA and larger)

2000-3000 kVA

- Low voltages: 460Y/265, 480Y/277, 480Δ, 4160Y/2400, 2400Δ, 2400/4160Y/2400

Standard Features:

1. Four lifting lugs
2. Bolted-on terminal compartment (18" or 24" deep depending on KVA) with removable front sill
3. Hinged, lift-off cabinet doors
4. Interlocked penta-head bolt/padlock handle operates a cam assembly which is part of the 3-point door latching mechanism. (A hex-head bolt is available.)

5. For live front construction, externally clamped high voltage porcelain bushings with a single eyebolt, clamp-type connector (accommodates #6 AWG solid to 250 MCM stranded conductors)
6. For dead front construction, externally clamped high voltage bushing wells for loadbreak or non-loadbreak inserts
7. Lightning arrester mounting pads (live front only)
8. Tank ground pads (1 in HV, 1 in LV)
9. Steel high/low voltage compartment barrier
10. One 1/2" penta-head bolt must be removed from the flange formed on the steel high/low barrier before the HV door can be opened (1/2" hex-head bolt available as an option).
11. Externally clamped low voltage bushings with threaded copper stud for full load current below 2100 amps. Externally clamped integral low voltage bushings for current above 2100 amps. NEMA spades provided per ANSI hole requirements
12. Nameplate
13. Fill plug and self-actuating pressure relief device
14. Drain plug
15. Removable neutral ground strap
16. Five-legged core/coil assembly
17. Handhole cover bolted onto tank top (protected by weathercover)
18. Panel-type coolers
19. NEMA safety labels
20. The paint finish process applies a durable, corrosion resistant finish to the product. The multi-step process includes an epoxy primer uniformly applied by cationic electrodeposition and a urethane top coat
21. Externally-operated tap changers



Optional Features:

Primary Termination

- Externally-clamped bushing wells with loadbreak or non-load-break inserts
- Integral loadbreak bushings

Secondary Termination

- Externally-clamped bushings with NEMA 6-hole, 8-hole, 10-hole, or 12-hole spades
- Spade supports are available. They are provided for 8-hole spades and larger when the current is 1400 amps or greater

Primary Switching

- LBOR oil switch: one for radial
- One, two, or three for loop feed
- 4 position T-blade or V-blade

Voltage Switching Options

- Externally-operated dual voltage switch
- Externally-operated delta-wye switch

Overcurrent Protection

- Internal primary protective links
- Bayonet-type expulsion fuses
- Drawout, loadbreak current limiting fuses, with or without interlocking transformer switch
- Secondary oil circuit breaker
- Internal, partial-range current limiting fuses

Overvoltage Protection

- Distribution class, metal oxide arresters, 3-36 kV
- Distribution class, valve-type lightning arresters, 3-27 kV

Construction Options

- 18", 24" and 30" deep terminal cabinet
- Drain valve and sampling device
- Mounting plate for CT's or PT's
- Interphase barriers
- Molded case external secondary breaker
- Substation Accessories – Oil gauge, thermometer, drain valve and sampler, pressure-vacuum gauge provision
- Weathercover
 - Transformers may feature an optional weathercover over the cabinet which is hinged to allow clearance for replacement of the bayonet-type fuses.
 - The weathercover can be lifted easily into place and secured with a single supporting arm.
 - The weathercover requires no additional holddown hardware.

Some optional features are not available on larger kVA units.

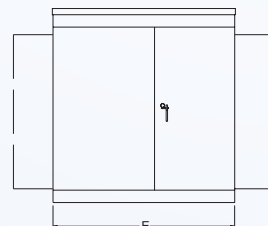
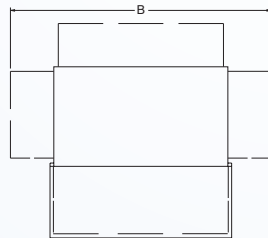

Live Front, Radial Feed

IEEE Fig. 1, 2, and 3 (C57.12.22)

KVA	A	B	C	D	E	Wt.	Gal. of Oil
75	56	56	44.8	44.8	56	2280	115
112	56	56	44.8	44.8	56	2400	115
150	56	56	44.8	44.8	56	2700	125
225	56	56	49.8	46.8	56	3350	150
300	56	60	50.8	46.8	56	3650	165
500	60	66	58.8	48.8	56	5200	200
750	68	81	60.8	50.8	66	7100	270
1000	68	84	62.8	54.8	66	7900	320
1500	68	86	66.8	58.8	66	9700	390
2000	72	96	76.8	62.8	70	12800	430
2500	72	100	78.8	62.8	70	14100	500
3000	76	132	90	66	70	20000	600

Dead Front, Radial Feed

IEEE Fig. 1, 3, and 4 (C57.12.26)

KVA	A	B	C	D	E	Wt.	Gal. of Oil
75	48	62	44.8	44.8	56	2350	115
112	48	62	44.8	44.8	56	2450	115
150	48	62	44.8	44.8	56	2700	125
225	48	62	49.8	46.8	62	3400	150
300	48	62	50.8	46.8	62	3700	165
500	56	66	58.8	48.8	62	5400	200
750	60	81	60.8	50.8	66	7100	270
1000	68	84	62.8	54.8	66	7900	320
1500	68	86	66.8	58.8	66	9700	390
2000	72	96	76.8	62.8	70	12800	430
2500	72	100	78.8	62.8	70	14100	500
3000	76	132	90	66	70	20000	600

Dead Front, Loop Feed

IEEE Fig. 2, 3, and 4 (C57.12.26)

KVA	A	B	C	D	E	Wt.	Gal. of Oil
75	56	66	44.8	44.8	56	2400	120
112	56	66	44.8	44.8	56	2500	120
150	56	66	44.8	44.8	56	2800	130
225	56	66	49.8	46.8	62	3500	160
300	56	66	50.8	46.8	62	3800	170
500	56	68	58.8	48.8	62	5600	200
750	68	82	60.8	50.8	66	7400	270
1000	68	86	62.8	54.8	66	8200	320
1500	68	88	66.8	58.8	66	10300	390
2000	72	96	76.8	62.8	70	12800	430
2500	72	100	78.8	62.8	70	14100	500
3000	76	132	90	66	70	20000	600

Design Dimensions and Weights:

(All weights and dimensions are approximate. Dimensions may change to meet specific customer requirements.

Weights are in pounds. Dimensions are in inches.)



ABB Inc.
Distribution Transformers
 500 West Highway 94
 Jefferson City, MO 65101
 USA
 Phone +1 573 634 2111
 Fax +1 573 659 6275
www.abb.com/transformers



UCT-Three Phase Underground Commercial Transformer

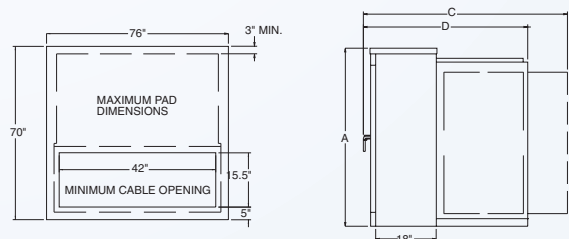
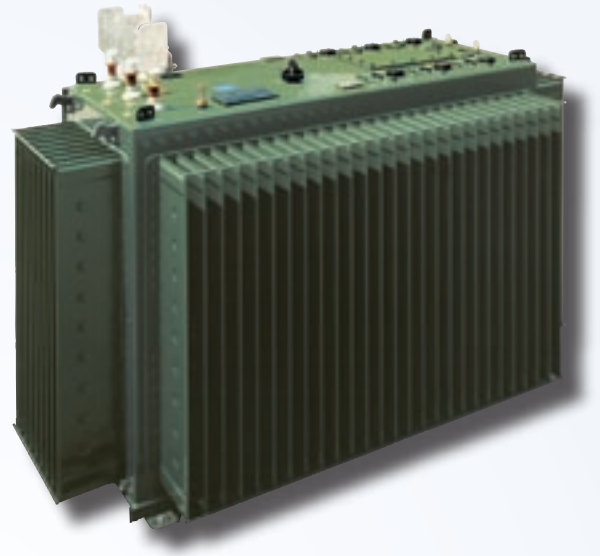

The UCT is a commercial or residential three phase transformer suited for diverse applications. It is designed for use in underground vaults and offers application flexibility, safety, and easy accessibility for operating personnel.

The UCT is designed for loop feed, dead front application, and is offered with bayonet fusing or drywell current limiting fuse protection interlocked with an LBOR oil loadbreak rotary switch for maximum safety.

Standard Features

1. Six welded-in 200A high voltage universal bushing wells for loop feed. Parking stands are located near each bushing for attachment of bushing accessories.
2. Bolted-on handhole cover(s)
3. Stainless steel ground pads
4. The paint finish process applies a durable, corrosion resistant finish to the product. The multi-step process includes an epoxy primer uniformly applied by cationic electrodeposition and a urethane top coat.
5. Oil fill plug and oil drain plug
6. Secondary bushings:
 - a. 750 kVA and below: welded-in bushings with threaded studs.
 - b. 1000-1500 kVA: externally clamped 6-hole spade bushings, >2100 AMPS.
7. Nameplate
8. Four lifting lugs

Optional Features

1. Bayonet fusing
2. Three drywell current limiting fuse canisters and current limiting fuses
3. Three phase (LBOR) externally operated loadbreak oil rotary switch with interlock to prevent removal of fuses when switch is in closed position
4. Radial feed configuration
5. Externally operable HV tap changer
6. Externally operable HV dual voltage switch
7. Rotatable spade type secondary bushings, 750 kVA and below
8. Pressure relief device

Ratings

75-1500 kVA, 3 phase, 55° C average winding rise.

60 hertz standard, 50 hertz optional

High Voltages (125 kV BIL and below)

A. Grounded Wye system 4160 Grd Y/2400 through 24940 Grd Y/14400

B. Delta System 2400Δ through 16340Δ

Low Voltages (30 kV BIL)

208Y/120

216Y/125

416Y/240

460Y/265

480Y/277

240Δ

480Δ



Design Dimensions and Weights

(All weights and dimensions are approximate. Dimensions may change to meet specific customer requirements.)

kVA	A Inches	B Inches	C Inches	D Inches	W Inches	X Inches	Weight Lbs.
75	52	60	31	31	62	62	3500
112.5	52	60	31	31	62	62	3700
150	52	60	31	31	62	62	4000
225	52	60	31	38	62	62	4800
300	56	67	31	42	62	76	5000
500	56	67	31	44	62	76	6200
750	64	75	33	46	70	90	9500
1000	64	75	35	52	70	90	10500
1500	68	80	39	68	70	102	15000



ABB Inc.
Distribution Transformers
 500 West Highway 94
 Jefferson City, MO 65101
 USA
 Phone +1 573 634 2111
 Fax +1 573 659 6275
www.abb.com/transformers



ABB Inc.
Distribution Transformers
500 West Highway 94
Jefferson City, MO 65101
USA
Phone +1 573 634 2111
Fax +1 573 659 6275
www.abb.com/transformers

Note:
We reserve the right to make technical changes or modify the contents of this document without prior notice.
With regard to purchase orders, the agreed particulars shall prevail. ABB does not accept any responsibility whatsoever for potential errors or possible lack of information in this document.
We reserve all rights in this document and in the subject matter and illustrations contained therein. Any reproduction – in whole or in parts – is forbidden without ABB's prior written consent.
Copyright © 2007 ABB

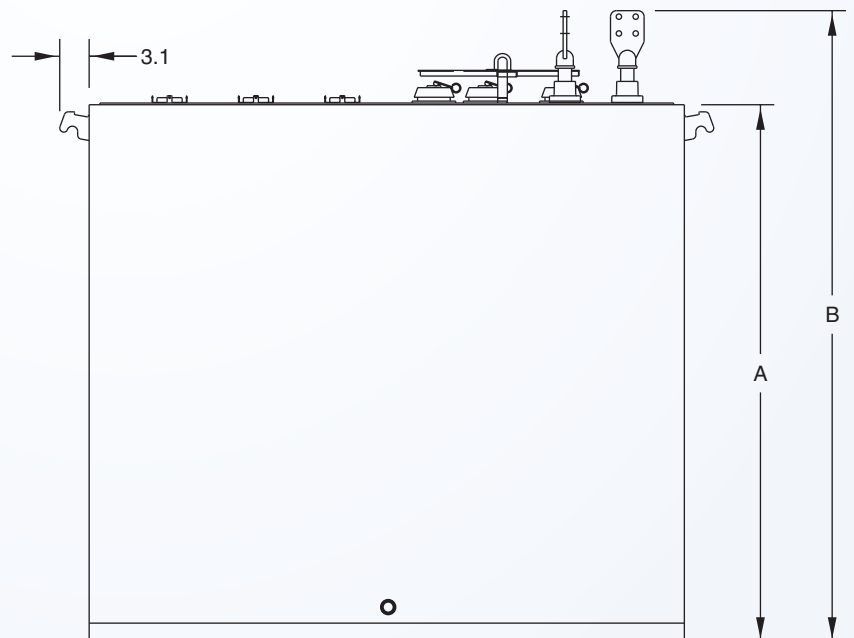
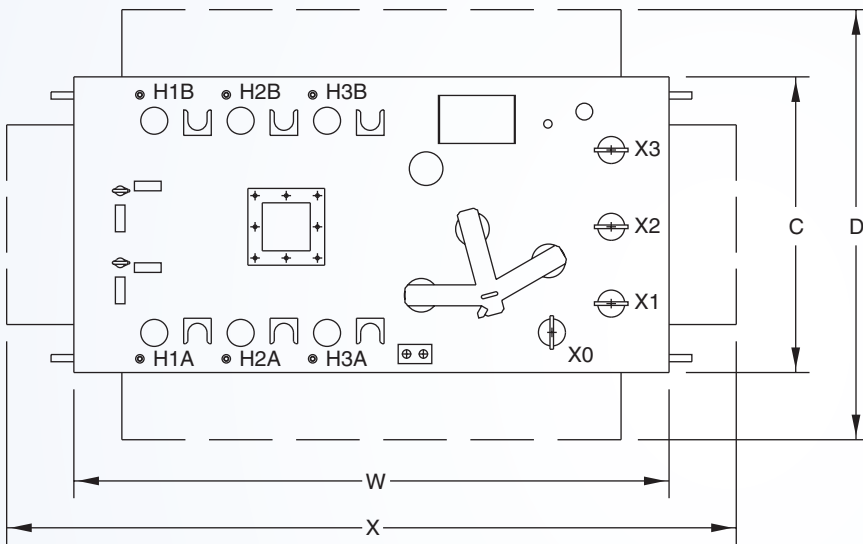
1LUJ 460300-LTE printed in USA (04.07 - 300 copies)